



Laboratory for Fire Safety

Summary of a fire resistance tests:

Bostik FP 401 acrylic sealant connecting stone to stone and gypsum to gypsum

On behalf of Bostik, four tests were performed in the Peutz Laboratory for Fire Safety for determination of the fire resistance of several linear joint seals with Bostik FP 401 acrylic sealant (further called Bostik FP 401) in walls of aerated concrete and / or gypsum. The tests were performed in accordance with the European standard EN 1366-4:2006+A1:2010 using the standard heating curve.

This summary provides an outline of the product performance and the conclusions of the test. For a complete description of the examined linear joint seals, please refer to the reports mentioned in the footnote.

Based on the tests performed in accordance with EN 1366-4:2006+A1:2010 and the extended application in accordance with EN 15882-4:2012, the system was classified in accordance with EN 13501-2:2007+A1:2009 and EN 13501-2:2016. Taking into account the possible classification times mentioned in the standard, a linear joint seal made out of Bostik FP 401, is classified according to the following combinations of performance parameters and classes.

Fire resistance classification (vertical linear joint seals in a stone wall)		
Stone to stone wall thickness ≥ 115 mm		Stone to stone Wall thickness ≥ 100 mm
Bostik FP 401 unexposed face Bostik FP 404 exposed face	Bostik FP 401 applied at unexposed face	Bostik FP 401 applied at both faces
EI 180 – V – X – F – W 8 to 30	EI 45 – V – X – F – W 5 to 20	EI 120 – V – X – F – W 5 to 30
EI 240 – V – X – F – W 8	EI 240 – V – X – F – W 5	EI 180 – V – X – F – W 5 to 10
E 240 – V – X – F – W 8 to 30	E 240 – V – X – F – W 5 to 20	E 240 – V – X – F – W 5 to 30

E = Criterion integrity, I = Criterion insulation, V = Vertical application in a vertical wall, X = No movement applied, F = Splice applied in the field, W = Permitted width range in millimetres

This summary consists out of 5 pages. The classification reports that form the basis for this summary are available for inspection at the client and are registered as YB 1567-1E-RA-002 dated June 24, 2015, YB 1692-1E-RA-002 dated September 16, 2016 and 18565C dated September 28, 2017.	Reference HL/HL//YQ 1692-2E-RA-002 13 September 2018	Page 1/5	Initials
---	---	--------------------	---------------------

The following conditions apply:

- the classifications are valid for linear joint seals in a wall with an orientation as mentioned (vertical);
- the linear joint seals may be applied in any type of wall of aerated concrete (class G4/600 or heavier), concrete, limestone or masonry with a minimal thickness as mentioned (100 or 115 mm);
- the surfaces of the material on which Bostik FP 401 and Bostik FP 404 (PU foam) is applied are thoroughly cleaned and treated with primer and moistened with water when needed. Except for the fully filled linear joint seals, the use of suitable PE / PU backing material is mandatory;
- the depth of Bostik FP 401 depends on the width of the linear joint seal. The minimum depth of Bostik FP 401 in relation to the width of the linear joint seal is shown in Graph 1 below. The depth of the sealant may also be increased with respect to the Graph (the lines are the minimum and recommended seal depth). If applicable, the rest of the slot is fully filled with Bostik FP 404 (PU foam);
- the allowed movement capability in practice is maximized to 7.5 %;
- when Bostik FP 401 is applied at both faces, the classifications are valid for both directions. When Bostik FP 401 is applied at one face, the classifications are valid for Bostik FP 401 at the unexposed face.

Graph 1: Minimum seal depth in relation to the seal width

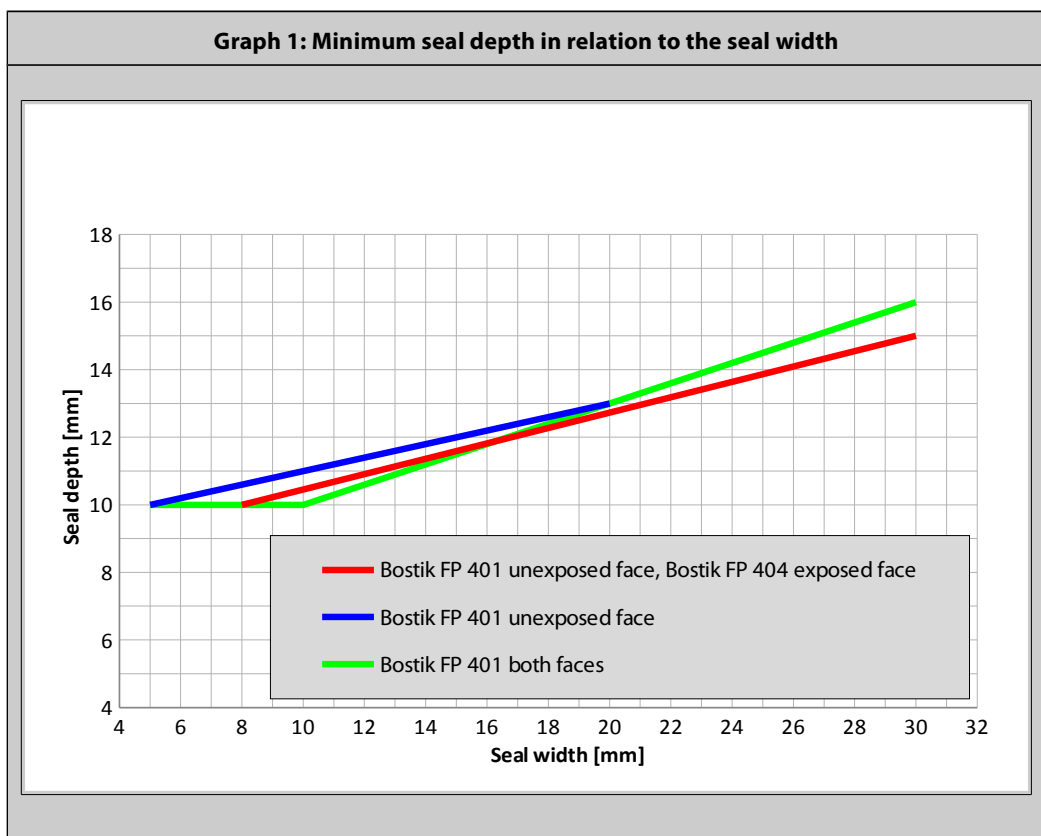

<p>This summary consists out of 5 pages. The classification reports that form the basis for this summary are available for inspection at the client and are registered as YB 1567-1E-RA-002 dated June 24, 2015, YB 1692-1E-RA-002 dated September 16, 2016 and 18565C dated September 28, 2017.</p>	<p>Reference HL/HL//YQ 1692-2E-RA-002 13 September 2018</p>	<p>Page 2/5</p>	<p>Initials <i>[Signature]</i></p>
--	--	----------------------------	---

Fire resistance classification (horizontal linear joint seals in a stone wall and a wall abutting a floor, ceiling or roof)
Applied connecting stone to stone, thickness wall ≥ 100 mm
Bostik FP 401 applied at both faces EI 180 – T – M 5 – F – W 10 to 30 E 240 – T – M 5 – F – W 10 to 30

E = Criterion integrity, I = Criterion insulation, T = Horizontal application in a vertical wall, M = Movement induced in %, F = Splice applied in the field, W = Permitted width range in millimetres

The following conditions apply:

- the classifications are valid for linear joint seals in a wall and a wall abutting a floor, ceiling or roof with an orientation as mentioned (horizontal);
- the linear joint seals may connect to any type of construction of aerated concrete (class G4/600 or heavier), concrete, block work or masonry with a minimal thickness as mentioned (100 mm);
- the surfaces of the material on which Bostik FP 401 is applied are thoroughly cleaned and treated with Primer when needed;
- the use of suitable PE / PU backing material is mandatory;
- the required depth of Bostik FP 401 depends on the width of the linear joint seal. The minimum depth of Bostik FP 401 in relation to the width of the linear joint seal is shown in Graph 2 below. The required depth of the sealant may also be increased with respect to the Graph (the lines are the minimum and recommended seal depth);
- deformation of the linear joint seals in practice is maximized to 7.5 %;
- the classifications are valid for both directions.

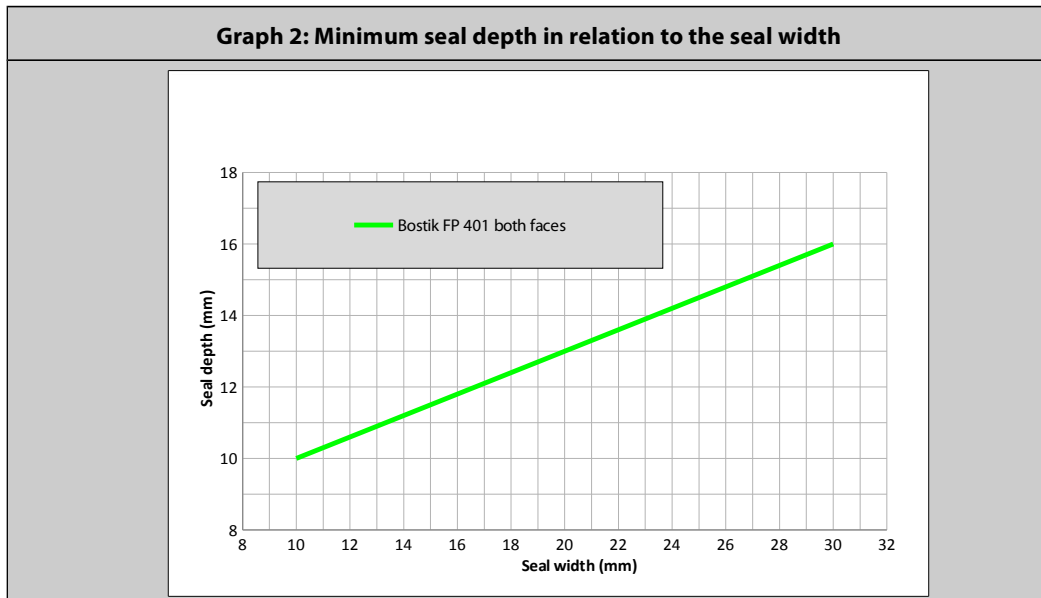

This summary consists out of 5 pages. The classification reports that form the basis for this summary are available for inspection at the client and are registered as YB 1567-1E-RA-002 dated June 24, 2015, YB 1692-1E-RA-002 dated September 16, 2016 and 18565C dated September 28, 2017.

Reference

HL/HL//YQ 1692-2E-RA-002
13 September 2018

Page

3/5

Initials

HL

Fire resistance classification (vertical linear joint seal in a flexible wall)		
Bostik FP 401 applied at both faces connecting gypsum to gypsum		Bostik FP 401 applied at both faces connecting gypsum to stone
Wall thickness ≥ 75 mm (see Figure 1)	Wall thickness ≥ 100 mm (see Figure 2)	Wall thickness ≥ 100 mm (see Figure 3)
EI 60 – V – X – F – W 10	EI 120 – V – X – F – W 10 E 180 – V – X – F – W 10	EI 120 – V – X – F – W 10 E 180 – V – X – F – W 10

E = Criterion integrity, I = Criterion insulation, V = Vertical application in a vertical wall, X = No movement applied, F = Splice applied in the field, W = Permitted width range in millimetres

The following conditions apply:

- the classifications are valid for linear joint seals in a wall with an orientation as mentioned (vertical);
- the linear joint seals in wall with a thickness ≥ 100 mm may connect on one side to any type of wall of aerated concrete (class G4/600 or heavier), concrete, block work, limestone or masonry with a minimal thickness as mentioned (100 mm). In practice, the metal profiles of the gypsum wall are mechanically fixed at a distance every 300 mm or less. Mechanically fixation of the metal profiles is mandatory;
- the linear joint seals may connect on both sided to a gypsum wall with a minimum thickness as mentioned (75 or 100 mm). In practice, the metal profiles of the gypsum wall are mechanically fixed at a distance every 300 mm or less. Mechanically fixation of the metal profiles is mandatory;
- the classifications are only valid for constructions shown in Figures 1 to 3;
- the surfaces of the material on which the sealant is applied are thoroughly cleaned and treated with primer when needed;
- the depth of Bostik FP 401 in a wall of 75 mm is 12.5 mm at both faces, representing the full thickness of the gypsum panel, see Figure 1. The depth of Bostik FP 401 in a wall of 100 mm is 10 mm at both faces. The rest of the cavity is filled up with suitable PE / PU backing material, see Figure 2 and 3;
- the allowed movement capability in practice is maximized to 7.5 %;
- the classifications are valid for both directions.

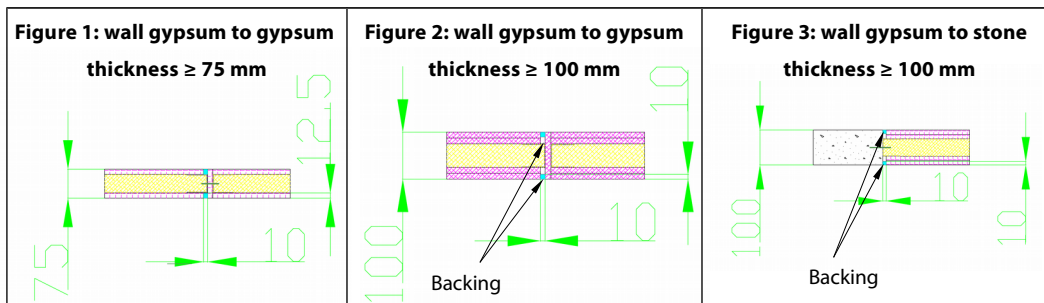

This summary consists out of 5 pages. The classification reports that form the basis for this summary are available for inspection at the client and are registered as YB 1567-1E-RA-002 dated June 24, 2015, YB 1692-1E-RA-002 dated September 16, 2016 and 18565C dated September 28, 2017.	Reference HL/HL//YQ 1692-2E-RA-002 13 September 2018	Page 4/5	Initials <i>[Signature]</i>
---	---	--------------------	---------------------------------------

Fire resistance classification (horizontal linear joint seals in a flexible wall)
Bostik FP 401 applied at both faces connecting gypsum to stone
Thickness wall ≥ 100 mm (see Figure 4) EI 120 – T – X – F – W 10 E 180 – T – X – F – W 10

E = Criterion integrity, I = Criterion insulation, T = Horizontal application in a vertical wall, X = No movement applied, F = Splice applied in the field, W = Permitted width range in millimetres

The following conditions apply:

- the classifications are valid for linear joint seals in a wall with an orientation as mentioned (horizontal);
- the linear joint seals in wall with a thickness ≥ 100 mm may connect on one side to any type of wall of aerated concrete (class G4/600 or heavier), concrete, block work, limestone or masonry with a minimal thickness as mentioned (100 mm). In practice, the metal profiles of the gypsum wall are mechanically fixed at a distance every 300 mm or less. Mechanically fixation of the metal profiles is mandatory;
- the linear joint seals may connect on the other side to a gypsum wall with a minimum thickness as mentioned (100 mm). In practice, the metal profiles of the gypsum wall are mechanically fixed at a distance every 300 mm or less. Mechanically fixation of the metal profiles is mandatory;
- the surfaces of the material on which Bostik FP 401 is applied are thoroughly cleaned and treated with Primer when needed;
- the use of suitable PE / PU backing material is mandatory;
- the depth of Bostik FP 401 in a wall of 100 mm is 10 mm at both faces. The rest of the cavity is filled up with suitable PE / PU backing material, see Figure 4;
- deformation of the linear joint seals in practice is maximized to 7.5 %;
- the classifications are valid for both directions.

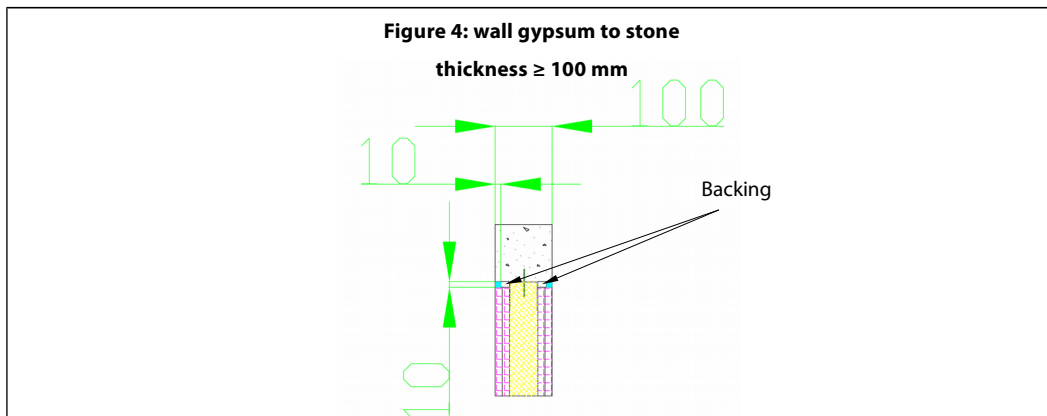

This summary consists out of 5 pages. The classification reports that form the basis for this summary are available for inspection at the client and are registered as YB 1567-1E-RA-002 dated June 24, 2015, YB 1692-1E-RA-002 dated September 16, 2016 and 18565C dated September 28, 2017.	Reference HL/HL//YQ 1692-2E-RA-002 13 September 2018	Page 5/5	Initials
---	---	--------------------	---------------------