



UL INTERNATIONAL (UK) LTD
 Kingsland Business Park,
 Unit 1-3 Horizon,
 Wade Rd,
 Basingstoke RG24 8AH,
 United Kingdom.



designated according to Article 29 of the Regulation (EU) No 305/2011 and member of EOTA (European Organisation for Technical Assessment, www.eota.eu)

European Technical Assessment

ETA 19/0395 of 12/07/2019

Technical Assessment Body issuing the ETA and designated according to Article 29 of the Regulation (EU) No 305/2011: UL International (UK) Ltd

Trade name of the construction product

Bostik FP 311 Intumescent Graphite

Product family to which the construction product belongs

Fire Stopping and Sealing Product:
 • Penetration Seals

Manufacturer

Bostik BV
 De Voerman 8,
 PO Box 303,
 5201 AH's-Hertogenbosch
 The Netherlands

Manufacturing plant(s)

A/003

This European Technical Assessment contains

22 pages including 1 Annex which forms an integral part of this assessment.

This European Technical Assessment is issued in accordance with regulation (EU) No 305/2011, on the basis of

EAD 350454-00-1104, September 2017.

Corrigendum No. 1

Translations of this European Technical Assessment in other languages shall fully correspond to the original issued document and should be identified as such.

Communication of this European Technical Assessment, including transmission by electronic means, shall be in full. However, partial reproduction may be made, with the written consent of the issuing Technical Assessment Body. Any partial reproduction has to be identified as such.

Table of Contents

I.	SPECIFIC PARTS OF THE EUROPEAN TECHNICAL ASSESSMENT	3
1	Technical description of the product	3
2	Specification of the intended uses of the product in accordance with the applicable European Assessment Document (Hereinafter EAD): EAD 350454-00-1104.....	3
3	Performance of the product and references to the methods used for its assessment	5
4	ASSESSMENT AND VERIFICATION OF CONSTANCY OF PERFORMANCE (HEREINAFTER AVCP) SYSTEM APPLIED, WITH REFERENCE TO ITS LEGAL BASE.....	6
5	Technical details necessary for the implementation of the AVCP system, as provided for in the applicable EAD	6
6	Issued on:.....	7
	ANNEX A – Resistance to Fire Classification – Bostik FP 311 Intumescent Graphite.....	8
	Flexible or rigid wall constructions with wall thickness of minimum 100 mm.....	8
A.1.1	Penetration seals, in drywalls* and concrete/masonry walls	8
A.1.2	Penetration seals with no backing material, in drywalls and concrete/masonry walls	10
A.2	Rigid walls constructions with wall thickness of minimum 150 mm	13
A.2.1	Penetration seals for pipes, in concrete/masonry walls	13
A.2.2	Penetration seals for cables, in concrete/masonry walls	14
A.2.3	Penetration seals for pipes, in concrete/masonry walls	15
A.3	Rigid floor constructions with floor thickness of minimum 150 mm.....	16
A.3.1	Penetration seals, surface mounted in concrete floors	16
A.3.2	Penetration seals, surface mounted in concrete floors	18
A.3.3	Penetration seals, surfaces mounted in concrete floors	19
A.3.4	Penetration seals, surface mounted in concrete floors	21

I. SPECIFIC PARTS OF THE EUROPEAN TECHNICAL ASSESSMENT

1 Technical description of the product

- 1) Bostik FP 311 Intumescent Graphite is a sealant and pipe closure device used to form penetration seals where insulated metallic pipes, combustible pipes, combustible cable conduits and cables penetrate walls and floors.
- 2) The Bostik FP 311 Intumescent Graphite is supplied in liquid form contained within 310 & 380 ml cartridges and 600 ml foil packs. The sealant is gunned into the aperture in the separating element and around the service or services, to a specified depth utilising mineral fibre insulation backing material.
- 3) The applicant has submitted a written declaration that the product and/or constituents of the product contains no substances which have been classified as dangerous according to Directive 67/548/EEC and Regulation (EC) No. 1272/2008 and listed in the 'indicative list on dangerous substances' of the EGDS – taking into account the installation conditions of the construction product and the release scenarios resulting from there.

In addition to the specific clauses relating to dangerous substances contained in this European Technical Assessment, there may be other requirements applicable to the products falling within its scope (e.g. transposed European legislation and national laws, regulations and administrative provisions). In order to meet the provisions of the Construction Products Regulation, these requirements need also to be complied with, when and where they apply.

- 4) The use category of Bostik FP 311 Intumescent Graphite in relation to BWR 3 (Hygiene, health and environment) is IA1, S/W3

2 Specification of the intended uses of the product in accordance with the applicable European Assessment Document (Hereinafter EAD): EAD 350454-00-1104

Detailed information and data is given in Annex A.

The intended use of system Bostik FP 311 Intumescent Graphite is to reinstate the fire resistance performance of flexible wall and rigid wall and floor constructions, where they are penetrated by services.

- 1) The specific elements of construction that the system Bostik FP 311 Intumescent Graphite may be used to provide a penetration seal in, are as follows:
 - Flexible walls: The wall must have a minimum thickness of 100 mm and comprise steel studs lined on both faces with minimum 2 layers of 12.5 mm thick boards. The walls must also incorporate a full fill core insulation of Stonewool (35kg/m³ density).
 - Rigid walls: The wall must have a minimum thickness of 100 mm and comprise concrete, aerated concrete or masonry, with a minimum density of 650 kg/m³.
 - Rigid floors: The floor must have a minimum thickness of 150 mm and comprise aerated concrete or concrete with a minimum density of 650 kg/m³.

The supporting construction must be classified in accordance with EN 13501-2 for the required fire resistance period.
- 2) The system Bostik FP 311 Intumescent Graphite may be used to provide a penetration seal with specific supporting constructions and substrates (for details see Annex A).

- 3) The provisions made in this European Technical Assessment are based on an assumed working life of the Bostik FP 311 Intumescent Graphite of 30 years, provided that the conditions laid down in the manufacturers datasheet and instructions for the packaging/transport/storage/installation/ use/repair are met. The indications given on the working life cannot be interpreted as a guarantee given by the producer, but are to be regarded only as a means for choosing the right products in relation to the expected economically reasonable working life of the works.
- 4) Type Z₂: intended for use at internal conditions with humidity classes other than Z₁, excluding temperatures below 0°C.

3 Performance of the product and references to the methods used for its assessment

Product-type: Sealant/Pipe closure		Intended use: Penetration Seal
Basic requirement for construction work	Basic Requirement	Performance
BWR 2 Safety in case of fire		
EN 13501-1	Reaction to fire	Class F (not tested)
EN 13501-2	Resistance to fire	Annex A
BWR 3 Hygiene, health and environment		
EN 1026	Air permeability	No performance determined
EAD 350454-00-1104, Annex C	Water permeability	No performance determined
Declaration of manufacturer & EN 16516	Content, emission and/or release of dangerous substances	Use categories: IA1, S/W3 Declaration of manufacturer
BWR 4 Safety in use		
EOTA TR 001:2003	Mechanical resistance and stability	No performance determined
EOTA TR 001:2003	Resistance to impact/movement	No performance determined
EOTA TR 001:2003	Adhesion	No performance determined
EAD 350454-00-1104, Clause 2.2.9	Durability	Z ₂
BWR 5 Protection against noise		
EN 10140-1,2,4,5/ EN ISO 717-1	Airborne sound insulation*	53 (0;-1) dB
BWR 6 Energy economy and heat retention		
EN 12664, EN 12667, EN 12939, EN ISO 8990, EN ISO 6946, EN ISO 14683, EN ISO 10211, EN ISO 10456	Thermal properties	No performance determined
EN ISO 12572, EN 12086, EN ISO 10456	Water vapour permeability	No performance determined

* At 25 mm depth

4 ASSESSMENT AND VERIFICATION OF CONSTANCY OF PERFORMANCE (HEREINAFTER AVCP) SYSTEM APPLIED, WITH REFERENCE TO ITS LEGAL BASE

According to the decision 1999/454/EC – Commission Decision of date 22nd June 1999 on the procedure for attesting the conformity of construction products pursuant to Article 20(2) of Council Directive 89/106/EEC as regards fire stopping, fire sealing and fire protective products, published in the Official Journal of the European Union (OJEU) L178/52 of 14/07/1999, see <http://eur-lex.europa.eu/JOIndex.do>) of the European Commission¹, as amended, the system(s) of assessment and verification of constancy of performance (see Annex V to Regulation (EU) No 305/2011) given in the following table(s) applies (apply).

Product(s)	Intended use(s)	Level(s) or class(es)	System(s)
Fire stopping and Fire Sealing Products	For fire compartmentation and/or fire protection or fire performance	Any	1

5 Technical details necessary for the implementation of the AVCP system, as provided for in the applicable EAD

Tasks of the manufacturer:

Factory production control

The manufacturer shall exercise permanent internal control of production. All the elements, requirements and provisions adopted by the manufacturer shall be documented in a systematic manner in the form of written policies and procedures, including records of results performed. This production control system shall ensure that the product is in conformity with this European Technical Assessment.

The manufacturer may only use initial / raw / constituent materials stated in the technical documentation of this European Technical Assessment.

The factory production control shall be in accordance with the Control Plan of 1st July 2014 relating to the European Technical Assessment ETA 19/0395 issued on 12/07/19 which is part of the technical documentation of this European Technical Assessment. The "Control Plan" is laid down in the context of the factory production control system operated by the manufacturer and deposited at UL International (UK) Ltd.

The results of factory production control shall be recorded and evaluated in accordance with the provisions of the Control Plan.

¹ Official Journal of the European Communities L178/52 of 14/7/1999

Other tasks of the manufacturer

Additional information

The manufacturer shall provide a technical data sheet and an installation instruction with the following minimum information:

(a) Technical data sheet:

- Field of application:
- Building elements for which the penetration seal is suitable, type and properties of the building elements like minimum thickness, density, and - in case of lightweight constructions – the construction requirements.
- Limits in size, minimum thickness etc. of the penetration seal
- Construction of the penetration seal including the necessary components and additional products (e.g. backfilling material) with clear indication whether they are generic or specific.

(b) Installation instruction:

- Steps to be followed
- Procedure in case of retrofitting
- Stipulations on maintenance, repair and replacement

6 Issued on:

12th July 2019

Report by:



D. Yates
Project Engineer
Building and Life Safety Technologies

Reviewed by:



C. Johnson
Staff Engineer
Building and Life Safety Technologies

For and on behalf of UL International (UK) Ltd.

ANNEX A – Resistance to Fire Classification – Bostik FP 311 Intumescent Graphite

Flexible or rigid wall constructions with wall thickness of minimum 100 mm

A.1.1 Penetration seals, in drywalls* and concrete/masonry walls

Penetration Seal: Combustible pipes sealed with Bostik FP 311 Intumescent Graphite, 25 mm deep to both sides of the wall backed with Stonewool (35kg/m³ density), 25 mm deep. Minimum separation between penetration seals of 30 mm (a₂).

Construction details:

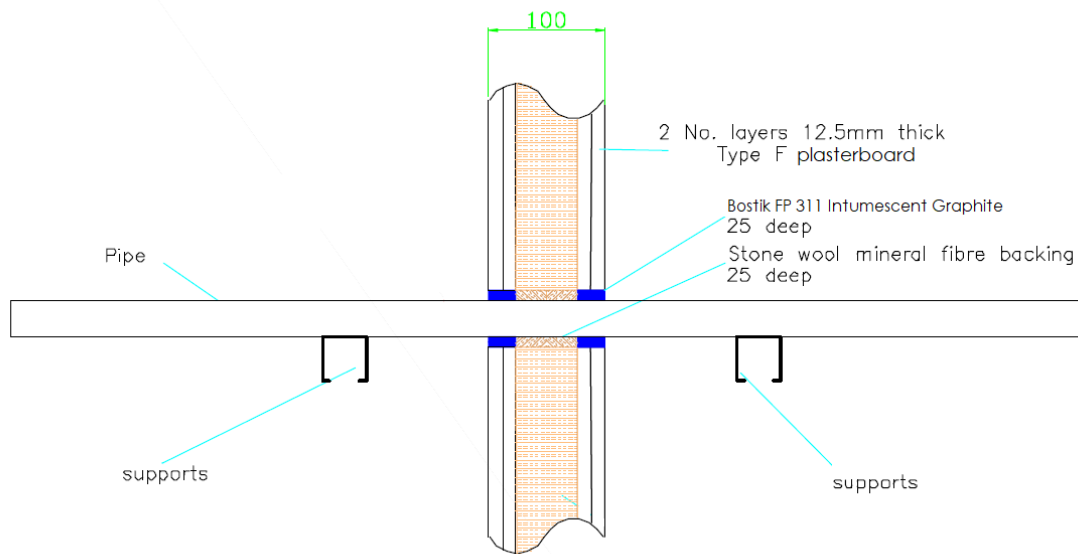

Configuration 1

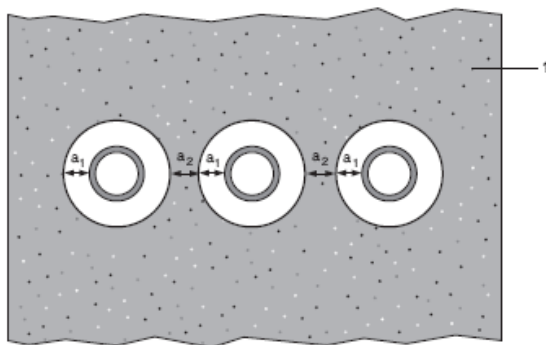

Configuration 2

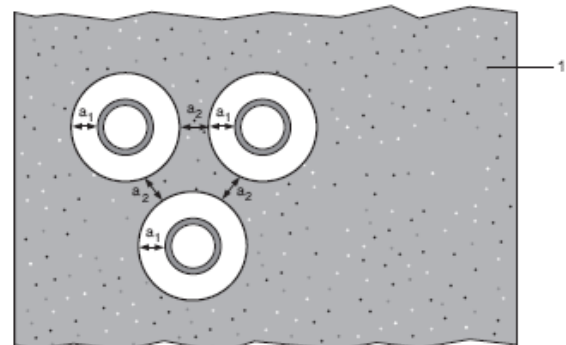

Key

1 Supporting construction

a₁ Pipe / edge of seal separation (annular space)

a₂ Separation between penetration seals

* Partition wall must incorporate a full fill core insulation of Stonewool (35kg/m³ density)

A.1.1.1

Services	Seal & Backing width (a1)	Permitted configuration for seal separation	Classification
PVC-U pipe according to EN 1329-1, EN 1452-2 and EN 1453-1, PVC-C according to EN 1566-1	10-30 mm	1 & 2 between PVC-U pipes	EI 120 U/C, EI 120 C/C
Diameter 40 mm, wall thickness 1.9 – 3.7 mm to diameter 110 mm, wall thickness 2.7-6.6 mm		1 & 2 between PVC-U pipes & between 40 mm Ø PE pipes	
Diameter 40, wall thickness 1.9 – 3.7 mm		1 & 2 between PVC-U pipes & between 40-110 mm Ø PE pipes	EI 60 U/C, EI 60 C/C
Diameter 40 mm, wall thickness 1.9 – 3.7 mm to diameter 110 mm, wall thickness 2.7-6.6 mm		1 & 2 between PVC-U pipes & between 110 mm Ø PP pipes	EI 120 U/C, EI 120 C/C
PE pipe according to EN 1519-1, EN 12201-2 and EN 12006-1, ABS according to EN 1455-1 and pipes made from SAN+PVC according to EN 1565-1			
Diameter 40 mm, wall thickness 2.4-3.7 mm	10-30 mm	1 & 2 between PE pipes & between 40 mm Ø PVC-U pipes	EI 120 U/C, EI 120 C/C
Diameter 40, wall thickness 2.4-3.7 mm to diameter 110 mm, wall thickness 4.3-10 mm		1 & 2 between PE pipes & between 40-110 mm Ø PVC-U pipes	EI 60 U/C, EI 60 C/C
Diameter 110 mm, wall thickness 4.3-10 mm		1 between PE pipes	E 120 U/C, E 120 C/C EI 90 U/C, EI 90 C/C
PP pipe according to EN 1852-1: 2009			
Diameter 110 mm, wall thickness 6.6 mm	30 mm	1 & 2 between 40-110 mm Ø PVC-U pipes	EI 120 U/C, EI 120 C/C
Diameter 40 mm, wall thickness 1.8 - 5.5 mm	10 mm	1 & 2	EI 90 U/C

A.1.2 Penetration seals with no backing material, in drywalls and concrete/masonry walls

Penetration Seal: Combustible cable conduit or combustible pipes sealed with Bostik FP 311 Intumescent Graphite, 25 mm deep to both sides of the wall without backing material. Minimum separation between penetration seals of 30 mm (a2).

Construction details:

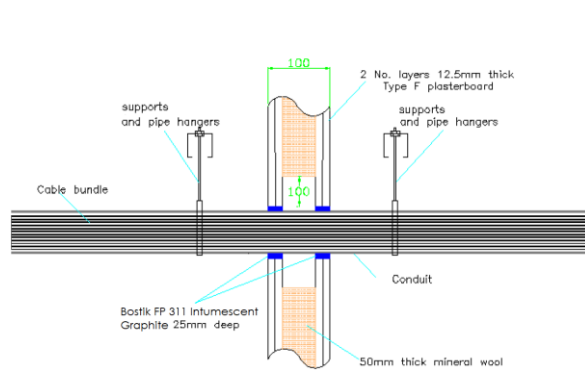

Construction details:

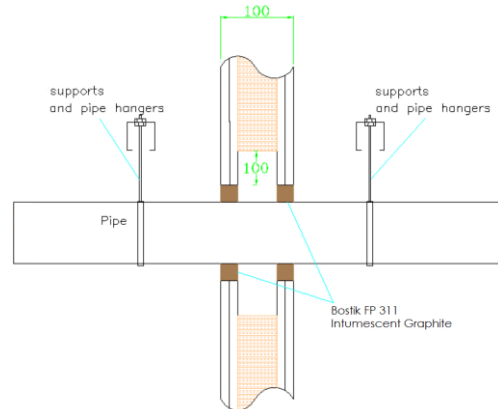

Construction details:

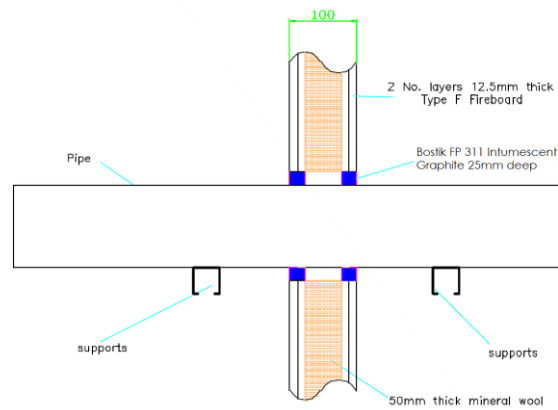

Configuration 1

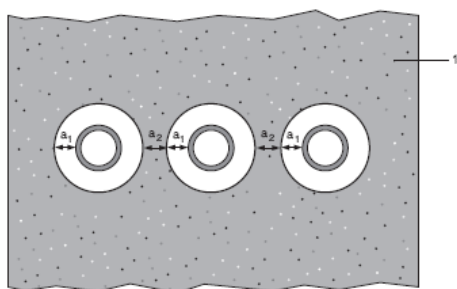

Configuration 2

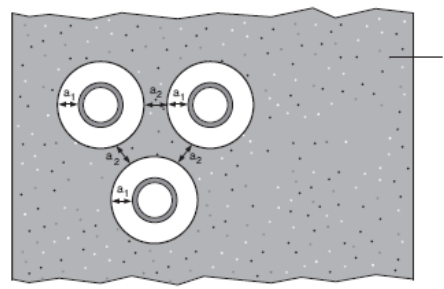

Key

1 Supporting construction

a1 Pipe / edge of seal separation (annular space)

a2 Separation between penetration seals

A.1.2.1

Services	Seal width (a1)	Permitted configuration for seal separation	Classification
PVC-U pipe according to EN 1329-1, EN 1452-2 and EN 1453-1, PVC-C according to EN 1566-1 or PP pipe according to EN 1852-1: 2009			
Maximum diameter 110 mm, wall thickness 1.9-6.6 mm for PVC pipes, fully or partially filled conduits with cables up to 20mm diameter	10-30 mm	1 & 2	EI 90 U/C
Maximum diameter 110 mm, wall thickness 2.7-6.6 mm for PP pipes, fully or partially filled conduits with cables up to 20mm diameter	10-30 mm	1 & 2	EI 90 U/C
PE pipe according to EN 1519-1, EN 12201-2 and EN 12006-1, ABS according to EN 1455-1 and pipes made from SAN+PVC according to EN 1565-1			
Maximum diameter 110 mm, wall thickness 2.4-10 mm, fully or partially filled conduits with cables up to 20mm conduit	10-30 mm	1 & 2	EI 60 U/C
PVC-U pipe according to EN 1329-1, EN 1452-2 and EN 1453-1, PVC-C according to EN 1566-1			
Maximum 160 mm diameter, wall thickness 3.2-9.5 mm	10-30 mm	1 & 2	EI 30 U/C
Maximum 160 mm diameter, wall thickness 9.5 mm	10-30 mm	1 & 2	EI 90 U/C
PP pipe according to EN 1852-1: 2009			
Maximum 110 mm, wall thickness 2.7 mm	10-30 mm	1 & 2	EI 60 C/C
Maximum 110 mm*	10-30 mm	1 & 2	EI 60 U/C

*See below graph for interpolation pipe sizes

PP Pipes- EI 60, U/C

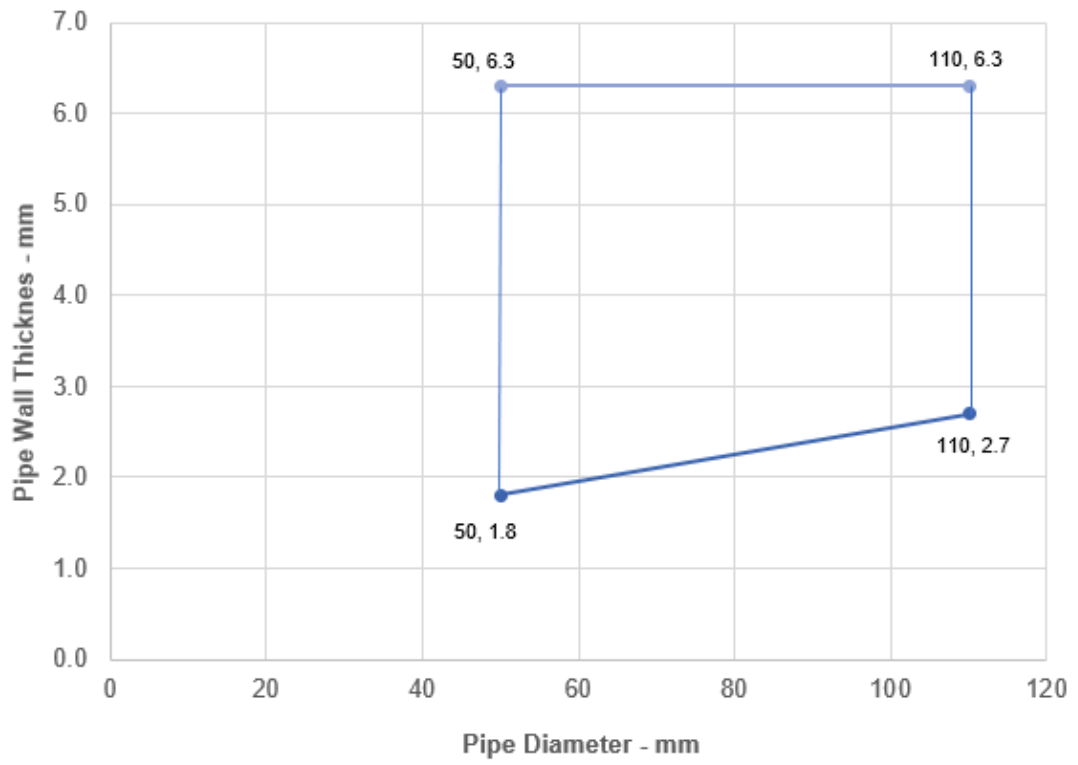

A.2 Rigid walls constructions with wall thickness of minimum 150 mm

A.2.1 Penetration seals for pipes, in concrete/masonry walls

Penetration Seal: Combustible pipes sealed with 40 mm deep Bostik FP 311 Intumescent Graphite, to both sides of the wall backed with Bostik FP 320 Fire Batt 2S, 50 mm thick. Minimum separation between penetration seals of 30 mm.

Construction details:

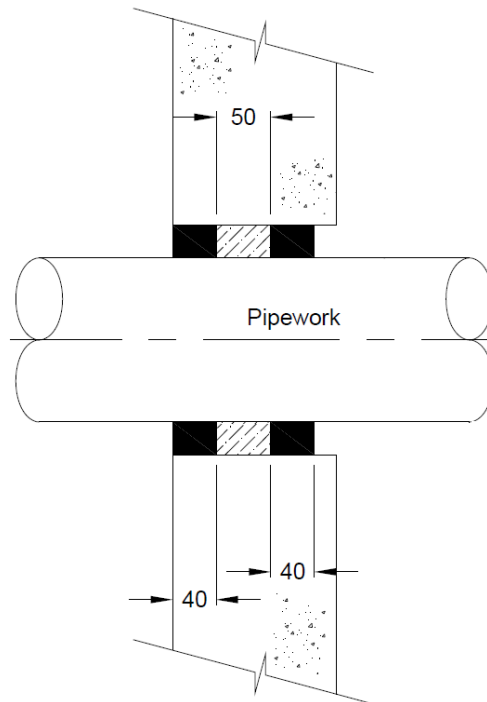

A.2.1.1

Services	Seal & Backing width	Classification
PVC-U pipe according to EN 1329-1, EN 1452-2 and EN 1453-1, PVC-C according to EN 1566-1		
Diameter 48 mm, wall thickness 3.2 mm	17 mm	EI 240 U/C, EI 240 C/C
Diameter 68 mm, wall thickness 2 mm	41 mm	
Diameter 110 mm, wall thickness 3.5 mm	22 mm	
PE pipe according to EN 1519-1, EN 12201-2 and EN 12006-1, ABS according to EN 1455-1 and pipes made from SAN+PVC according to EN 1565-1		
Diameter 32 mm, wall thickness 3.2 mm	25 mm	EI 240 U/C, EI 240 C/C
ABS pipe according to EN 1455-1		
Diameter 36 mm, wall thickness 2.3 mm	23 mm	EI 240 U/C, EI 240 C/C
Diameter 110 mm, wall thickness 3.5 mm	26 mm	

A.2.2 Penetration seals for cables, in concrete/masonry walls

Penetration Seal: Cables sealed with 40 mm deep Bostik FP 311 Intumescent Graphite, to both sides of the wall backed with Bostik FP 320 Fire Batt 2S, 50 mm thick. Minimum separation between penetration seals of 30 mm.

Construction details:

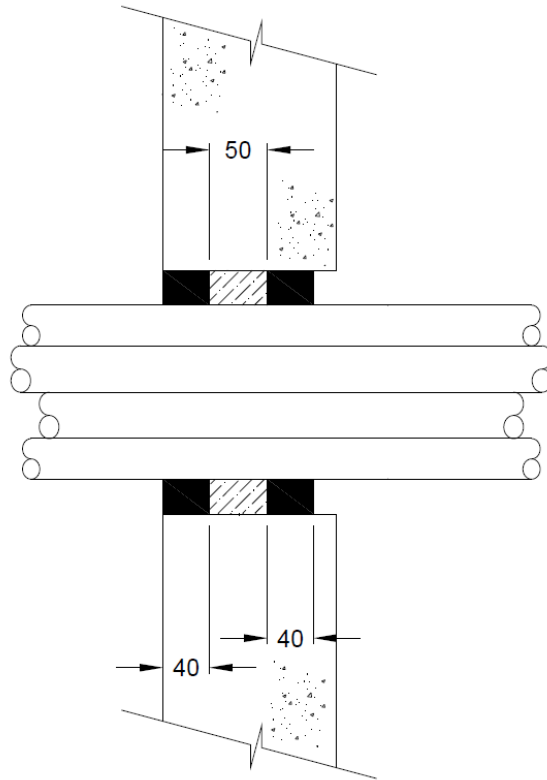

A.2.2.1

Services	Seal size (WxH or diameter)	Classification
150 x 25 mm perforated steel cable tray	200 x 100 mm	E 240, EI 180
20 mm diameter, single copper core armoured cable		
Twin/earth cable		
∅ 100 mm bundle of up to 4 no. 20mm diameter, single copper core armoured cable and 12 no. twin/earth cables	150 mm ∅	E240, EI 60

A.2.3 Penetration seals for pipes, in concrete/masonry walls

Penetration Seal: Combustible pipes sealed with 35 mm deep Bostik FP 311 Intumescent Graphite, to both sides of the wall backed with Mineral Bio backing material, 25 mm thick. Minimum separation between penetration seals of 30 mm.

Construction details:

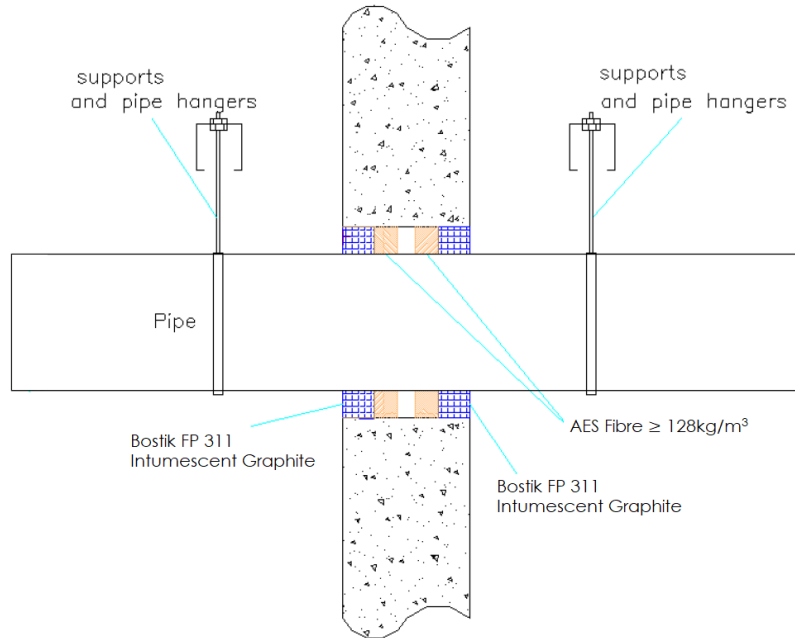

A.2.3.1

Services	Seal & Backing width (a1)	Classification
PVC-U pipe according to EN 1329-1, EN 1452-2 and EN 1453-1, PVC-C according to EN 1566-1		
Maximum 160 mm diameter, wall thickness 4.0-9.5 mm	10-30 mm	EI 90 U/C
Maximum 160 mm diameter, wall thickness 9.5 mm	10-30 mm	E 240, EI 180 U/C
PE pipe according to EN 1519-1, EN 12201-2 and EN 12006-1, ABS according to EN 1455-1 and pipes made from SAN+PVC according to EN 1565-1		
Maximum 160 mm diameter, wall thickness 4.9-9.5mm	10-30 mm	EI 30 U/C
PP pipe according to EN 1852-1: 2009		
Maximum 160 mm diameter, wall thickness 6.2-9.1 mm	10 mm	EI 30 U/C

A.3 Rigid floor constructions with floor thickness of minimum 150 mm

A.3.1 Penetration seals, surface mounted in concrete floors

Penetration Seal: Combustible pipes sealed with Bostik FP 311 Intumescent Graphite, to both sides of the floor backed with Stonewool (35kg/m³ density), 25 mm deep. Minimum separation between penetration seals of 30 mm.

Construction details:

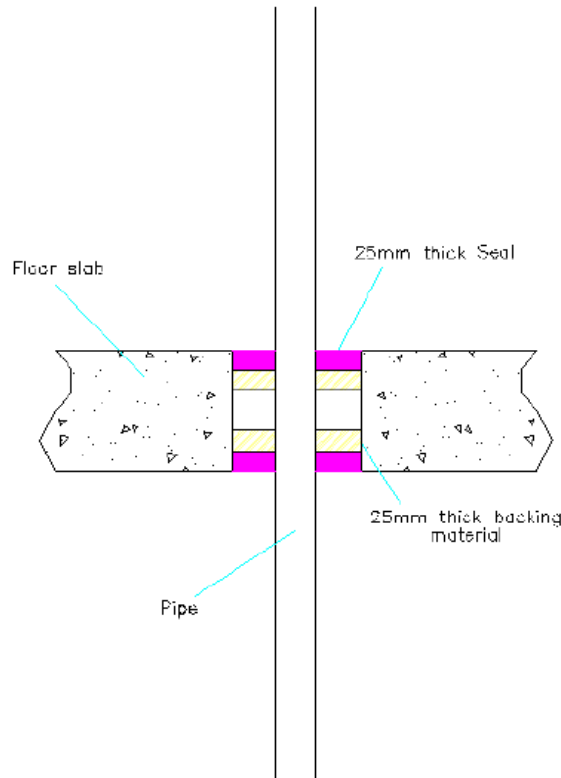

Configuration 1

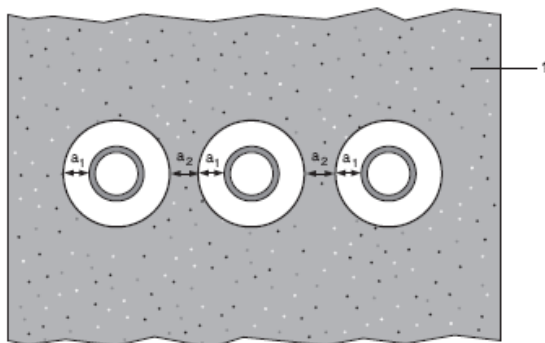

Configuration 2

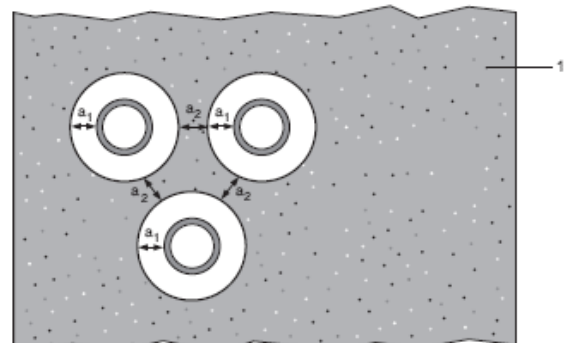

Key

- 1 Supporting construction
- a₁ Pipe / edge of seal separation (annular space)
- a₂ Separation between penetration seals

A.3.1.1

Services	Seal & Backing width	Permitted configuration for seal separation	Classification
PVC-U pipe according to EN 1329-1, EN 1452-2 and EN 1453-1, PVC-C according to EN 1566-1			
Diameter 40 mm, wall thickness 1.8 – 3.7 mm	10-30 mm	1 & 2 between PVC-U pipes	EI 240 U/U, EI 240 C/U, EI 240 U/C, EI 240 C/C
Diameter 40 mm, wall thickness 1.8 – 3.7 mm to diameter 110 mm, wall thickness 2.7-6.6 mm		1 & 2 between PVC-U pipes & between 40-110 mm Ø PE pipes	EI 90 C/U, EI 90 C/C
PE pipe according to EN 1519-1, EN 12201-2 and EN 12006-1, ABS according to EN 1455-1 and pipes made from SAN+PVC according to EN 1565-1			
Diameter 40 mm, wall thickness 2.4-3.7 mm	10-30 mm	2 between PE pipes	EI 60 U/U, EI 60 C/U, EI 60 U/C, EI 60 C/C EI 240 U/C, EI 240 C/C
Diameter 40, wall thickness 2.4-3.7 mm to diameter 110 mm, wall thickness 4.3-10 mm		1 & 2 between PE pipes & between 40-110 mm Ø PVC-U pipes	EI 60 U/C, EI 60 C/C
Diameter 110 mm, wall thickness 4.3-10 mm		2 between PE pipes	EI 90 U/C, EI 90 C/C
Diameter 110 mm, wall thickness 10 mm		2 between PE pipes	EI 60 U/U, EI 60 C/U, EI 60 U/C, EI 60 C/C

A.3.2 Penetration seals, surface mounted in concrete floors

Penetration Seal: Combustible pipes sealed with Bostik FP 311 Intumescent Graphite, 35 mm deep to both sides of the floor backed with AES Fibre $\geq 128\text{kg/m}^3$ (128kg/m^3 density), 25 mm deep. Minimum separation between penetration seals of 30 mm.

Construction details:

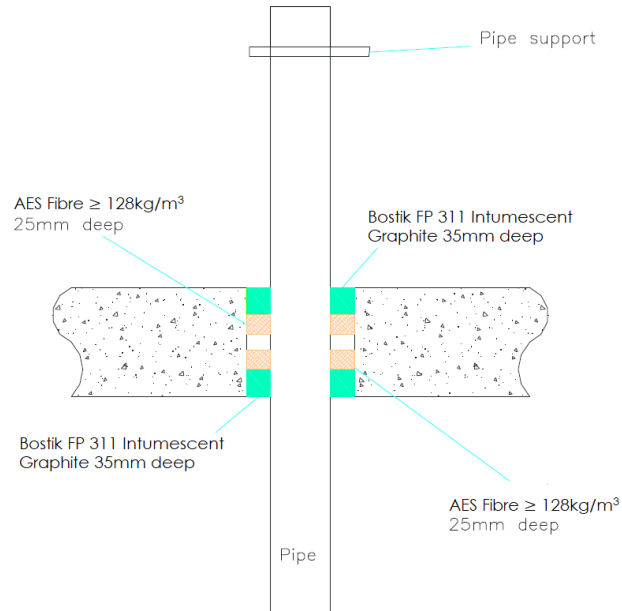

A.3.2.1

Services	Seal & Backing width (a1)	Classification
PVC-U pipe according to EN 1329-1, EN 1452-2 and EN 1453-1, PVC-C according to EN 1566-1		
Maximum 160 mm diameter, wall thickness 4.0-9.5mm	10-30 mm	EI 60 U/C
PE pipe according to EN 1519-1, EN 12201-2 and EN 12006-1, ABS according to EN 1455-1 and pipes made from SAN+PVC according to EN 1565-1		
Maximum 160 mm diameter, wall thickness 4.9-14.6 mm	10-30 mm	EI 30 U/C
Maximum 160 mm diameter, wall thickness 14.6 mm	10-30 mm	EI 60 U/C

A.3.3 Penetration seals, surfaces mounted in concrete floors

Penetration Seal: Combustible pipes sealed with Bostik FP 311 Intumescent Graphite, 25 mm deep to both sides of the floor backed with Rock mineral wool (33kg/m³ density), 25 mm deep. Minimum separation between penetration seals of 30 mm (a2).

Construction details:

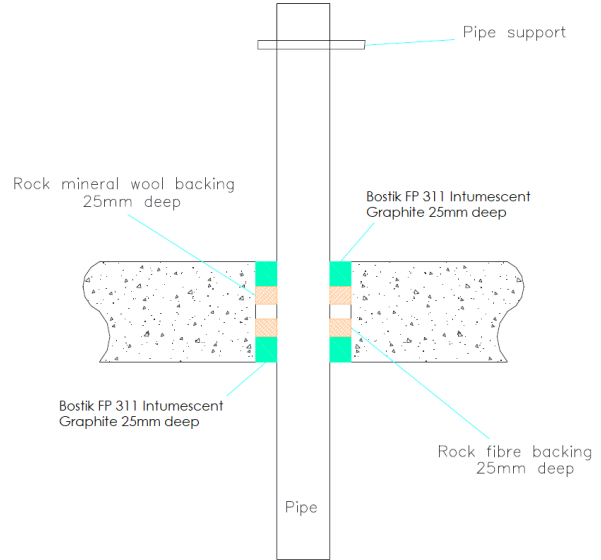
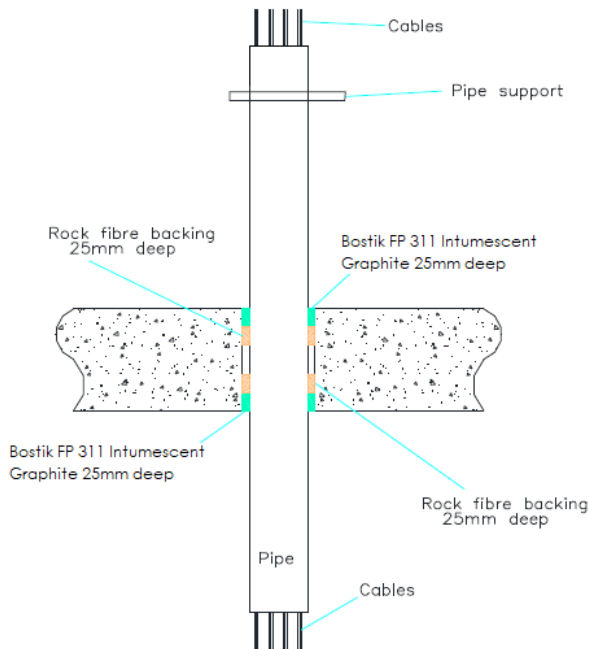

Configuration 1

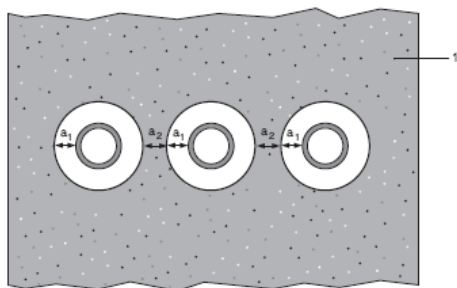

Configuration 2

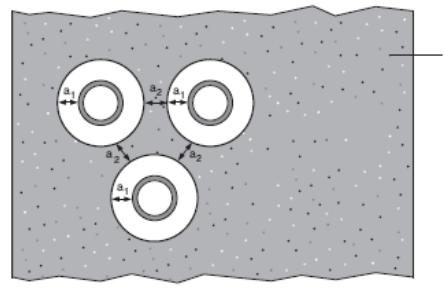

Key

- 1 Supporting construction
- a₁ Pipe / edge of seal separation (annular space)
- a₂ Separation between penetration seals

A.3.3.1

Services	Seal width (a1)	Permitted configuration for seal separation	Classification
PVC-U pipe according to EN 1329-1, EN 1452-2 and EN 1453-1, PVC-C according to EN 1566-1 or PP pipe according to EN 1852-1: 2009			
Maximum diameter 110 mm, wall thickness 1.8-6.6 mm for PVC pipes, fully or partially filled conduits with cables up to 20 mm diameter	10-30 mm	1 & 2	EI 90 U/C
Maximum diameter 110 mm, wall thickness 2.7 mm for PP pipes, fully or partially filled conduits with cables up to 20 mm diameter	10-30 mm	1 & 2	EI 90 U/C
Maximum diameter 110 mm, wall thickness 1.8-6.3 mm for PP pipes, fully or partially filled conduits with cables up to 20 mm diameter	10-30 mm	1 & 2	EI 30 U/C
PE pipe according to EN 1519-1, EN 12201-2 and EN 12006-1, ABS according to EN 1455-1 and pipes made from SAN+PVC according to EN 1565-1			
Maximum diameter 110 mm, wall thickness 2.4-10 mm, fully or partially filled conduits with cables up to 20 mm diameter	10-30 mm	1 & 2	EI 60 U/C
PP pipe according to EN 1852-1: 2009			
Maximum 40 mm diameter, wall thickness 1.8 mm	10-30 mm	1 & 2	EI 120 C/C
Maximum 110 mm diameter, wall thickness 1.8-6.3 mm	10-30 mm	1 & 2	EI 30 U/C

A.3.4 Penetration seals, surface mounted in concrete floors

Penetration Seal: Metallic pipes insulated with Elastomeric insulation minimum class B-s3, d0, Continuous Sustained (CS), sealed with Bostik FP 311 Intumescent Graphite, 45 mm deep to both sides of the floor and backed with AES Fibre $\geq 128\text{kg/m}^3$ (128kg/m³ density), 30 mm deep. Minimum separation between penetration seals of 30 mm (a2).

Construction details:

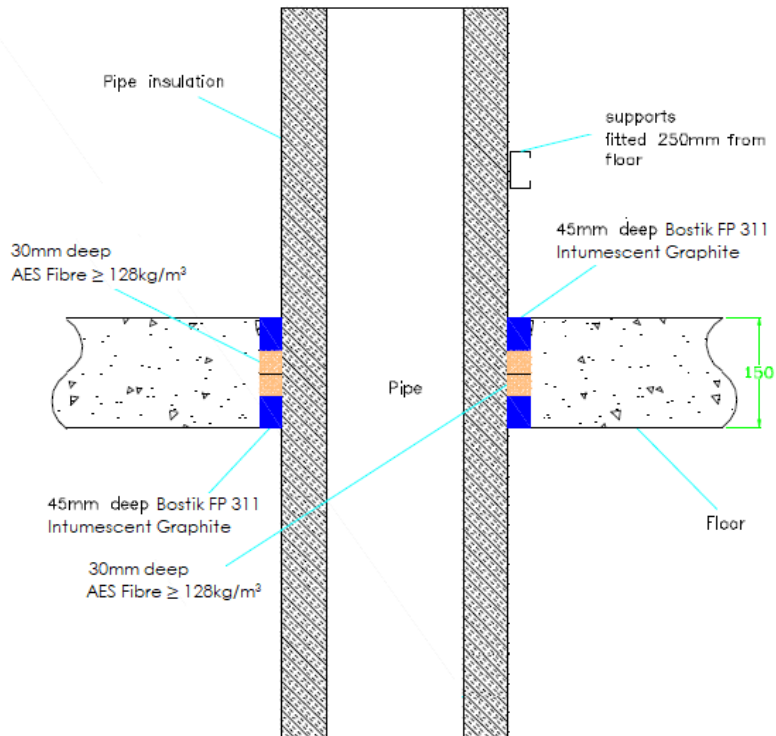

Configuration 1

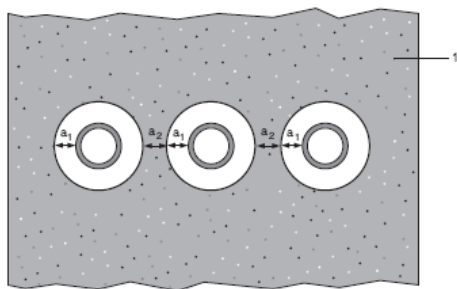

Configuration 2

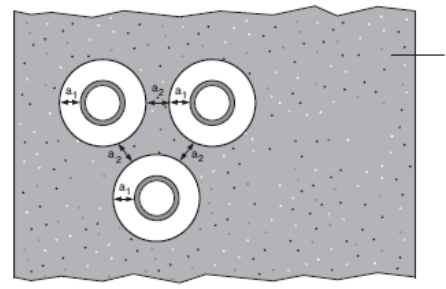

Key

- 1 Supporting construction
- a₁ Pipe / edge of seal separation (annular space)
- a₂ Separation between penetration seals

A.3.4.1

Services	Seal & backing material width (a1)	Permitted configuration for seal separation	Insulation CS	Classification
Mild or stainless steel pipe, with Elastomeric insulation minimum class B-s3, d0				
Maximum 324 mm diameter, wall thickness 1.0-14.2 mm	10-30 mm	1 & 2	25-50 mm Elastomeric insulation minimum class B-s3, d0	EI 60 C/U
Maximum 324 mm diameter, wall thickness 6.35-14.2 mm	10-30 mm	1 & 2	50 mm Elastomeric insulation minimum class B-s3, d0	EI 120 C/U